

NON PENETRATING
PICKHOLES.

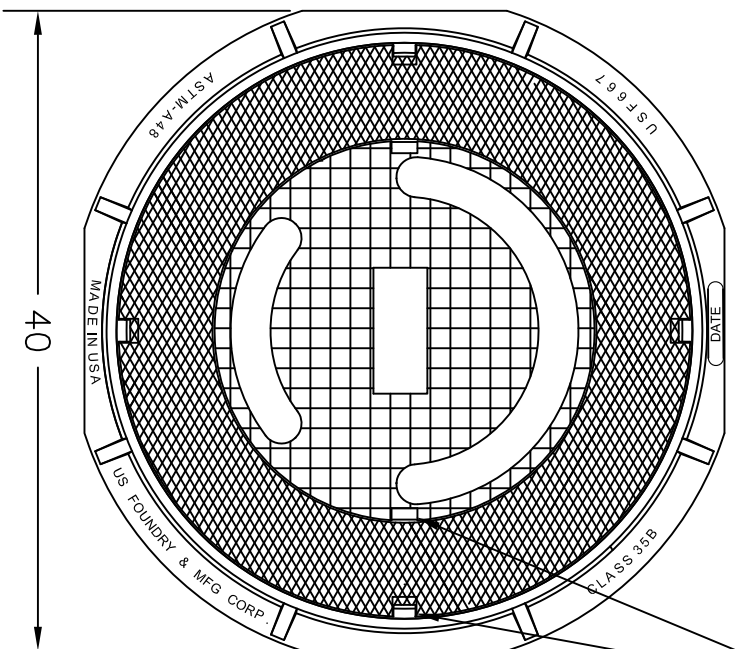

US FOUNDRY & MFG. CORP.
 8351 NW 93rd Street, Medley, FL 33166-2025
 ph: 1-800-432-9709; fax: 305-887-9429
 www.usfoundry.com
 © 2010 US Foundry & Mfg. Corp. All Rights Reserved

USF 667 RING & BJ COVER
 (CR DOUBLE COVER)

LOAD CLASSIFICATION: Heavy Duty			
MATERIAL:	ASTM-A48 GRAY IRON CLASS35B	SCALE:	1"=1"
Ring No:	8020188	WGHT:	220
Cover No:	200	DATE:	
Cover2 No:	220	DMN. BY:	HJF
UNLESS OTHERWISE NOTED WEIGHT IS IN POUNDS AND APPROXIMATED			
REV:	DATE:	REV BY:	QUOTE#