

COVER

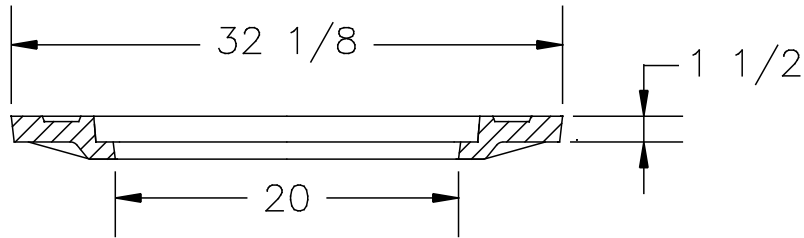

DOUBLE COVER

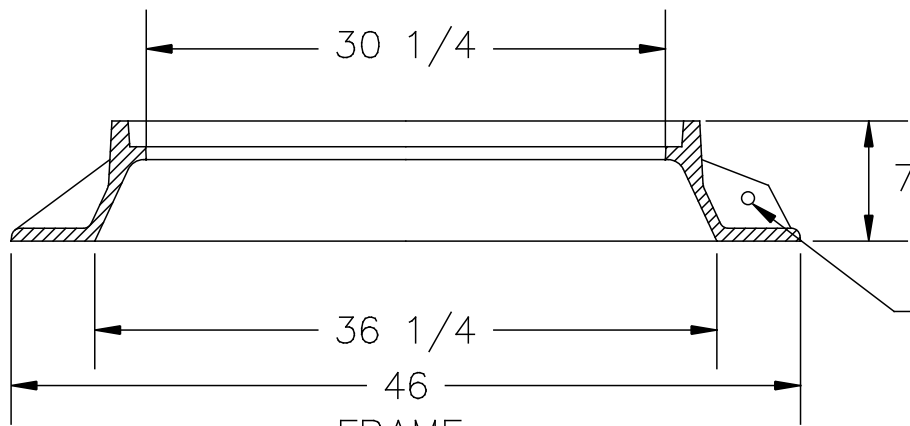

FRAME

(4) - NON PENETRATING PICKHOLES

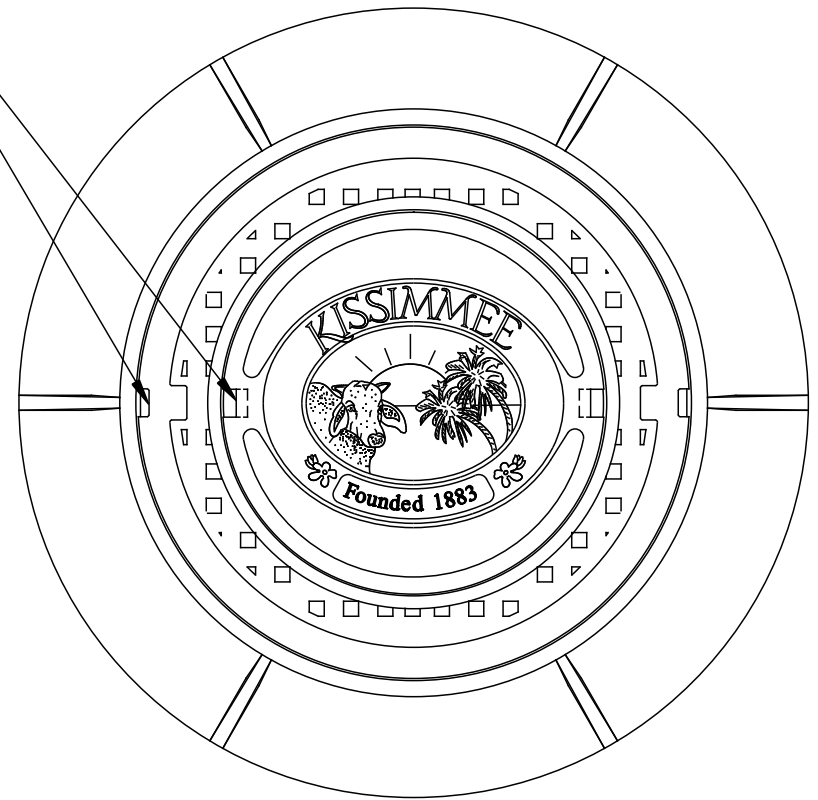

3 - 3/4" DIA. LIFTING HOLES

NOTES:

- 1- MATERIAL: ASTM-A48 CLASS 35B GRAY IRON
- 2- RING WT: 300 LBS. APP.
- 3- OUTER COVER WT: 190 LBS. APP
- 4- INNER COVER WT: 105 LBS. APP.



U.S. FOUNDRY & MFG. CORP.
MEDLEY, FLORIDA

USF 663 RING & AB/MB COVER

DWN. BY: DBB	SCALE: 1" = 1'-0"	DATE: 11/16/99
CHK. BY:	DWG. NO: A4731-R	REV: