

THE INFORMATION CONTAINED IN THIS DRAWING IS THE SOLE PROPERTY OF U.S. FOUNDRY & MANUFACTURING CORP. ANY REPRODUCTION IN PART OR AS A WHOLE WITHOUT THE WRITTEN PERMISSION OF U.S. FOUNDRY & MANUFACTURING CORP. IS PROHIBITED. U.S. FOUNDRY & MANUFACTURING CORP. RESERVES THE RIGHT TO MAKE MODIFICATIONS TO DESIGN WITHOUT PRIOR NOTICE. DRAWING IS UNCONTROLLED WHEN PRINTED. WEIGHTS AND DIMENSIONS ARE PROVIDED FOR REFERENCE ONLY. © 2015 US FOUNDRY AN EAGLE MANUFACTURING COMPANY

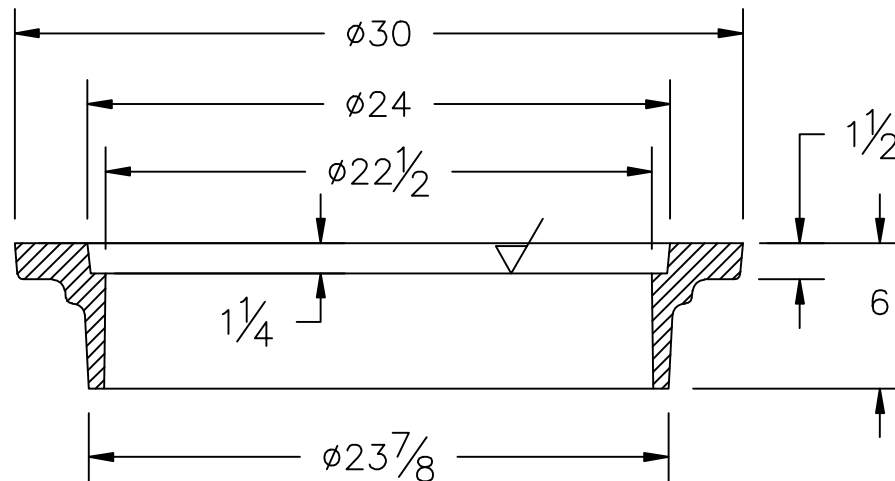
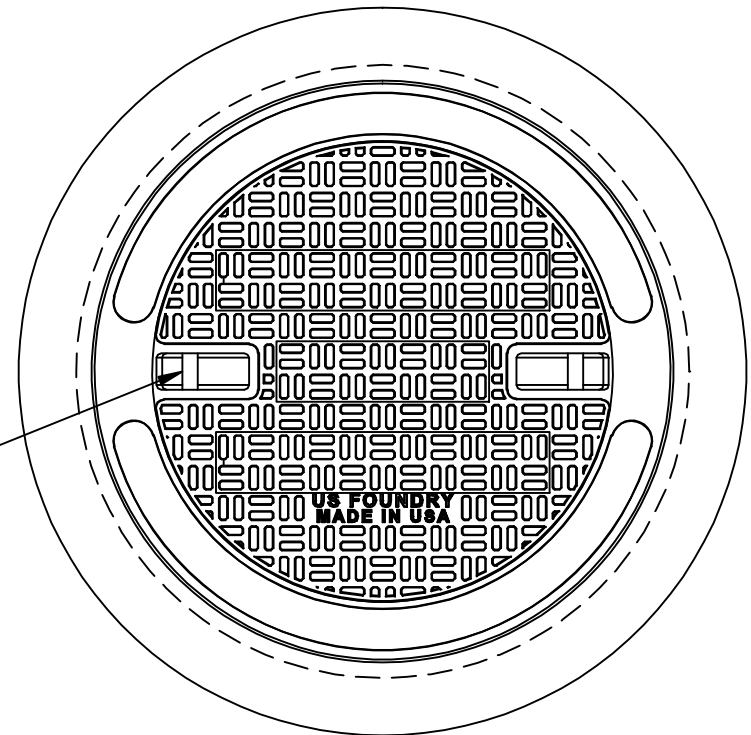
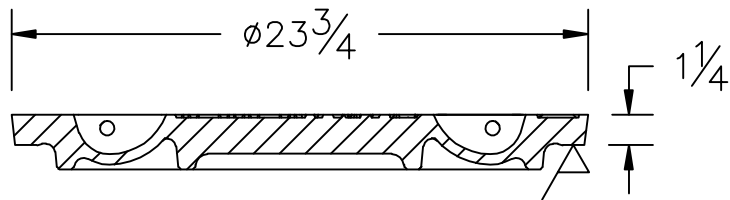

US FOUNDRY
 AN EAGLE MANUFACTURING COMPANY © 2015 All Rights Reserved

8351 NW 93rd Street
 Medley, FL, 33166-2025
 ph: 1-800-432-9709
 fax: 305-887-9429
 www.usfoundry.com

USF 1266 Ring & WS Cover			
LOAD CLASSIFICATION: Heavy Duty			
MATERIAL: ASTM-A48 GRAY IRON CLASS35B			
Ring No:	8020078	SCALE:	1/8"=1"
Cover No:		DATE:	7/15/2015
		OWN. BY:	ULS
REV: 0	DATE:	REV BY:	QUOTE#