

(2) NON-PENETRATING PICKHOLES.

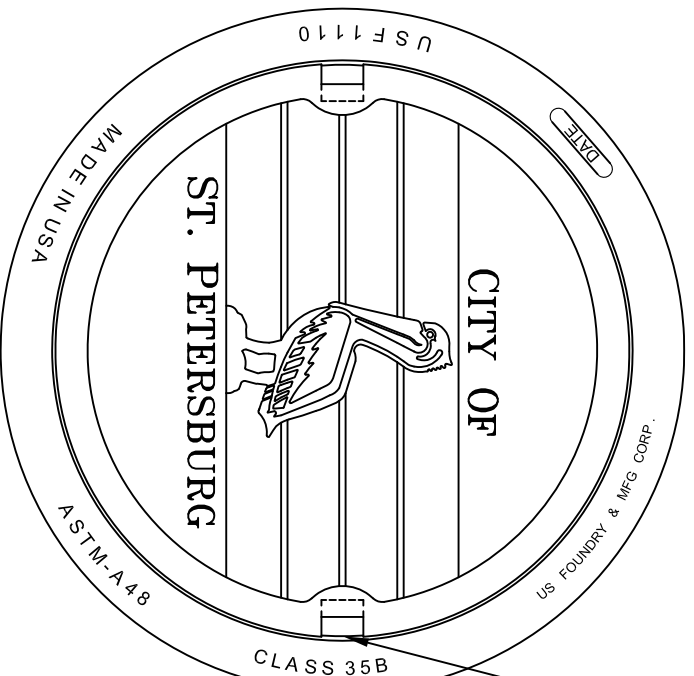
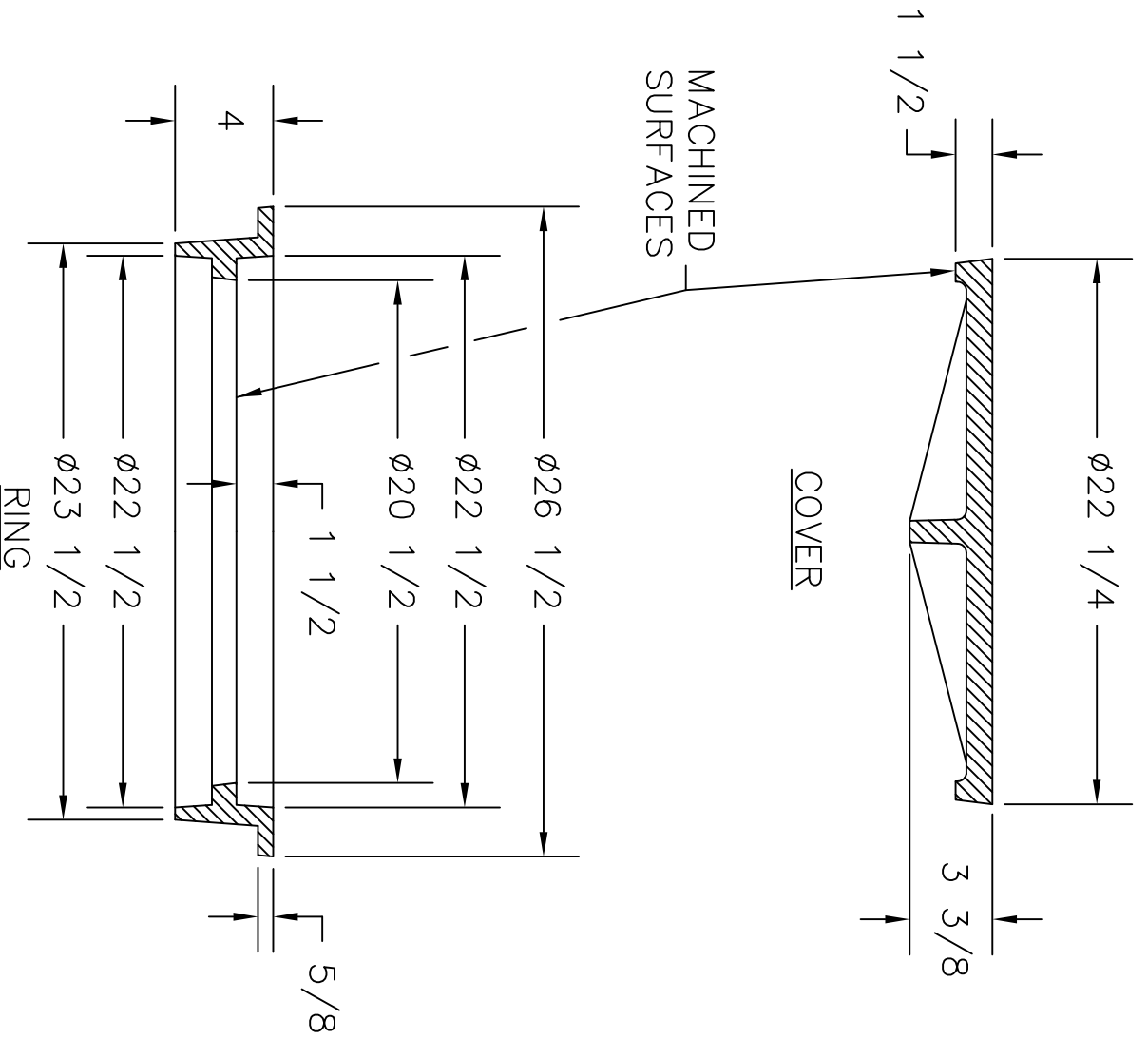

US FOUNDRY & MFG. CORP.
 8351 NW 93rd Street, Medley, FL 33166-2025
 ph: 1-800-432-9709; fax: 305-887-9429
 www.usfoundry.com
 © 2010 US Foundry & Mfg. Corp. All Rights Reserved

USF 1110 RING & EF COVER
 (M DRAG)

LOAD CLASSIFICATION: Heavy Duty	
MATERIAL: ASTM-A48 GRAY IRON CLASS 35B	CLASS: 35B
Ring No: 8020226	WGHT: 90
Cover No: 105	SCALE: 1/8"=1"
DATE:	DATE:
DNW. BY: DBB	DATE:
UNLESS OTHERWISE NOTED WEIGHT IS IN POUNDS AND APPROXIMATED	
REV: DATE:	REV BY: QUOTE#