

H:9B:CFA5HC B7CBH5B98 B H:68F5K B: 4GH:9GC@DFCD9FHC: 1'G':C1B8FM' A5BI:57HFB: 7CFD'5BMF9DFC817HC B 4D5FH  
 CF5G5K <C@K H:C1HH:9K F#H9B D9FA 4GCBC: 1'G':C1B8FM' A5BI:57HFB: 7CFD'6DFC <6H98'1'G':C1B8FM' A5BI:57HFB:  
 7CFD'F99FJ 9GH:9F# <HC A579A C8#75HCBGHC 89G# B K H:C1HDFCFBCH7 9'8F5K B: 4I B7CBHC@98 K <9B DF4H98'K 9# <HG  
 5B8 8A 9BGCBG5F9DFCJ 498:CF F9.9F9B79CB@M# 85% 1'G':C1B8FM5B'95; @9A5BI:57HFB: 7CAD5BM

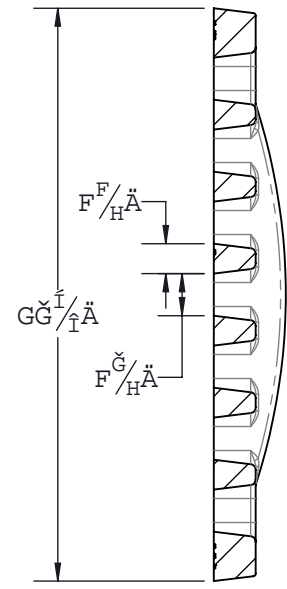

UÓÓÚŠSÁÑĚŇ

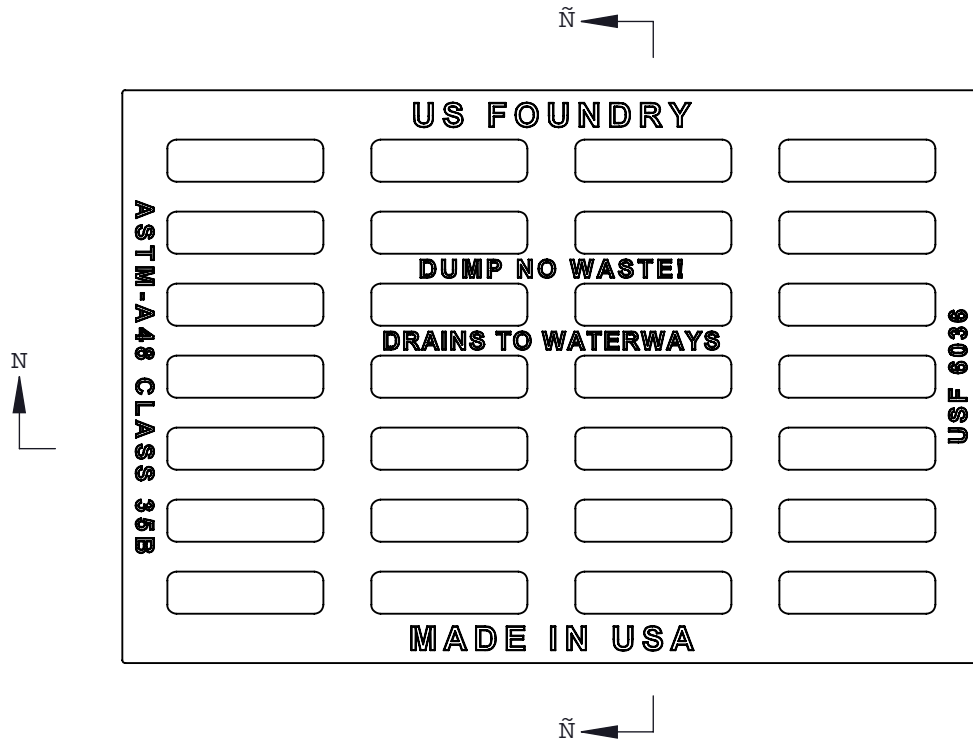
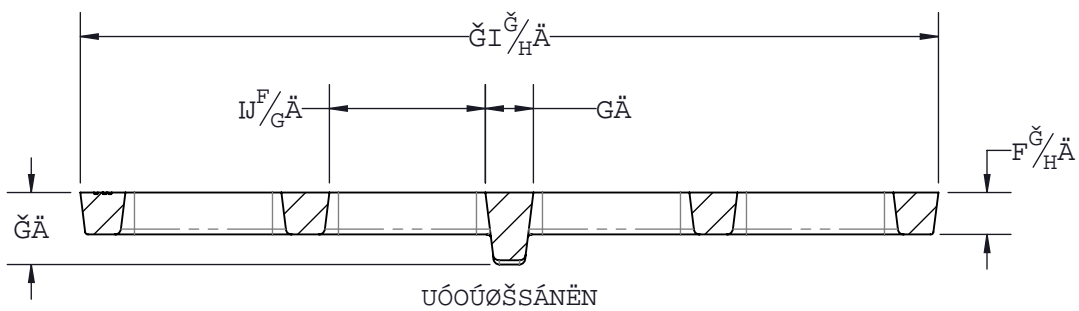

UÓÓÚŠSÁÑĚŇ

**US FOUNDRY**

AN EAGLE MANUFACTURING COMPANY

,')%BK ' fX'GhYYh  
 A YX'Ymž: @' ' %\*!&\$%)  
 d\.'d, \$\$!( ' &! - + \$-  
 žul .'' \$)! , , +! - (&-  
 k k k "i gžci bXfm'W@a  
 ' &\$%( '5'' F)[ \hg F YgYfj YX

I G: '* \$' * 'F YWUj[ i 'Uf'; fUHY	
@ 58 7 @6G# 7 5HC B.	J gcx{ 'F w{ : @C K '5F95. 53704lp
A 5H9F 5@	I tc{ 'Ecu'Kqp CUVO 'C/6: 'Encu'57D
#9A.	655B' k 9# <HVg 8F5K B: WUH8258
; fUHY	: 299326 442 <sup>85H</sup> 7434236
	8F5K B'6M WNU
I B@GGCH:9FK @9BCH98K 9# <H G B DCI B8G/ 5DDFLA5H9fi) l' 8C BCHG75@	
2 <sup>85H</sup>	62: 8

71 gřca Yf.8fuk ]bl