

COVER

MACHINED SURFACE

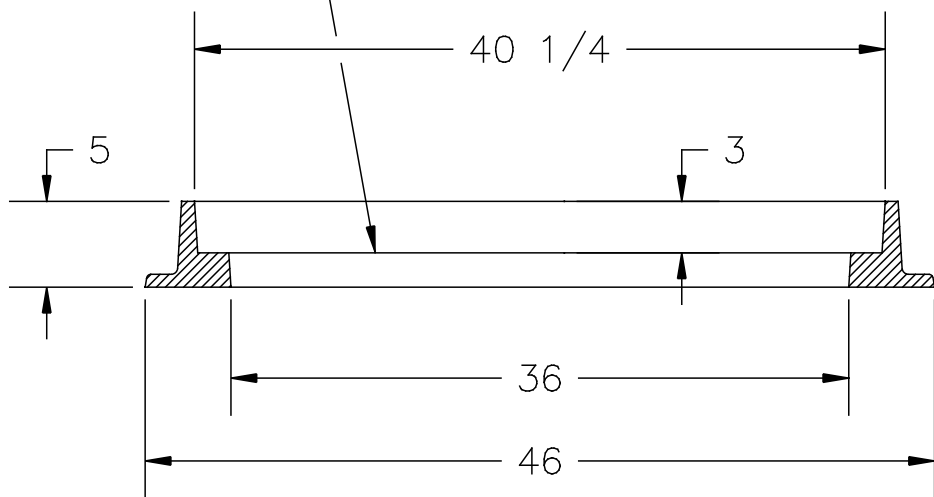

RING

NOTES:

- 1- COVER: STEEL, HOT DIP GALVANIZED AFTER FABRICATION.  
WEIGHT: 505 LBS. APP.
- 2- RING: ASTM-A48 CLASS 35B GRAY IRON.  
WEIGHT: 340 LBS. APP.
- 3- LOADING: 280 P.S.I.

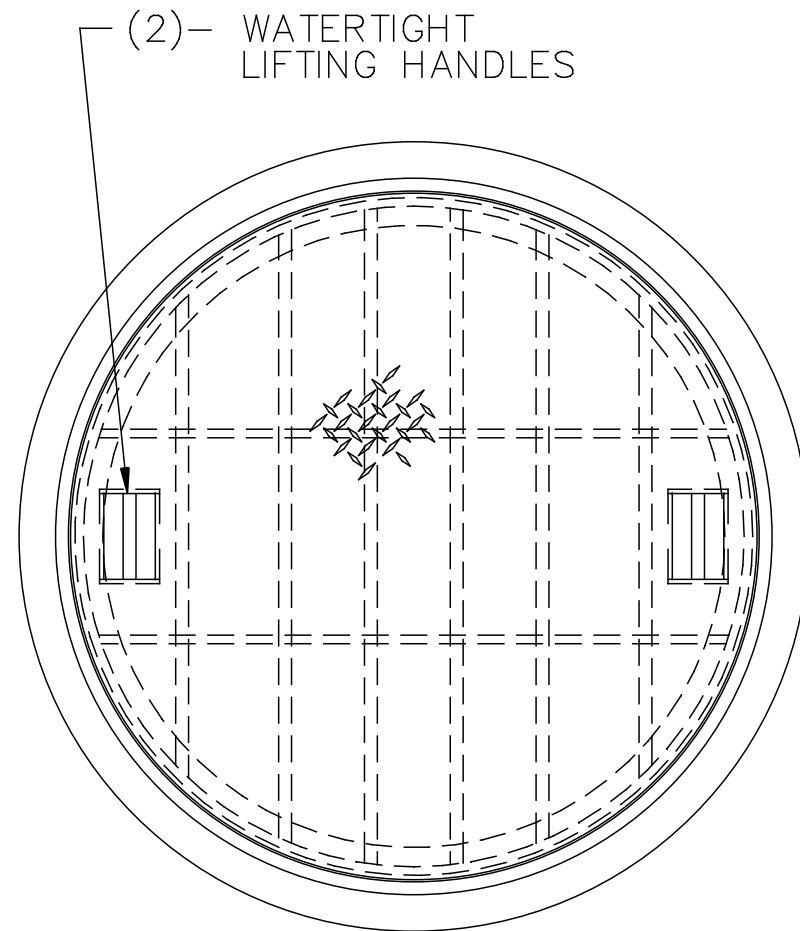

**U.S. FOUNDRY & MFG. CORP.**  
MEDLEY, FLORIDA

USF 8635 RING & GY COVER