

MACHINED SURFACE

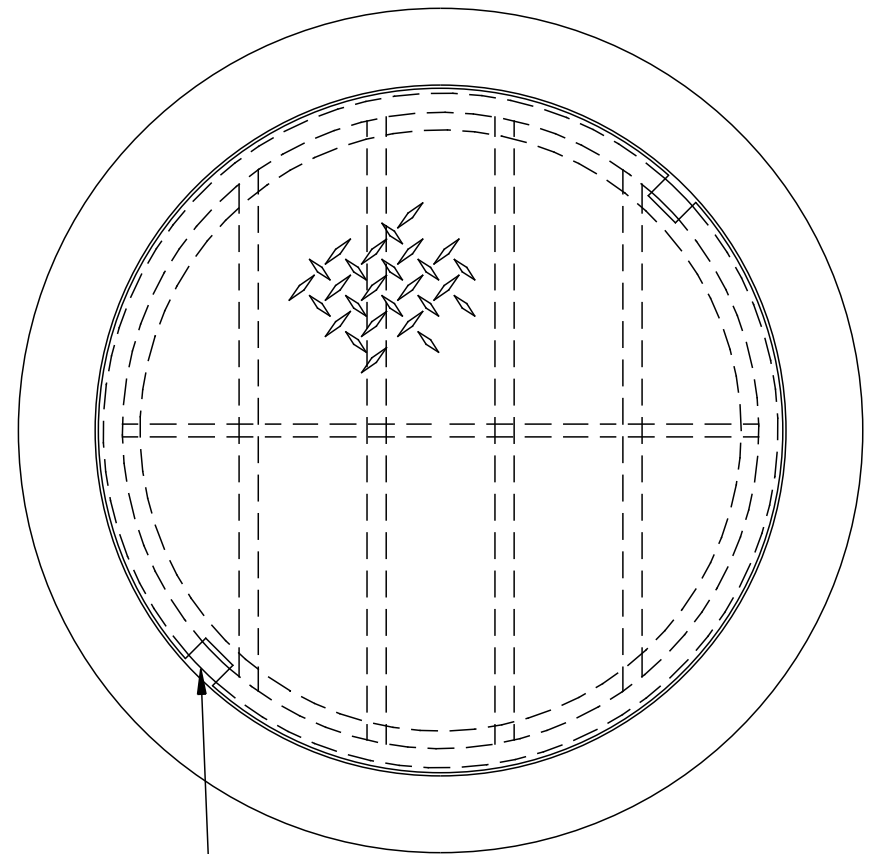
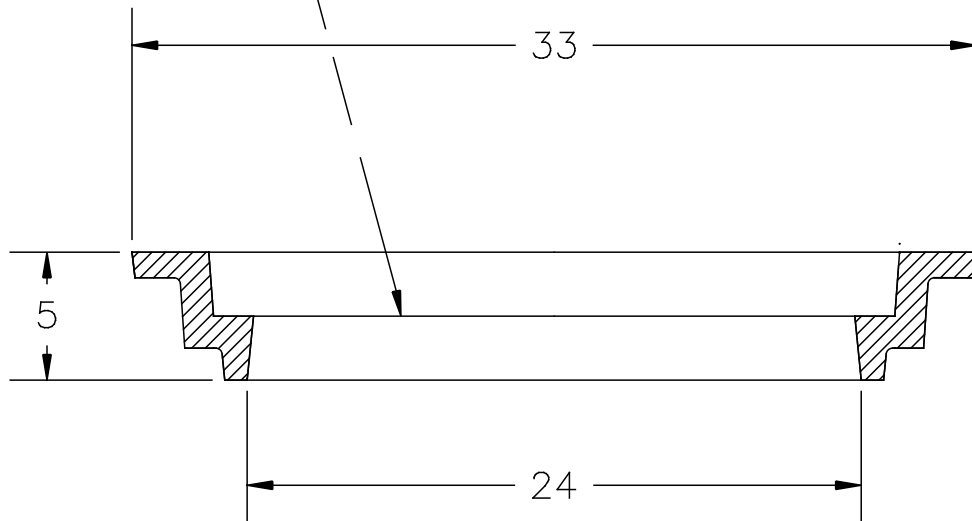

(2) - NON PENETRATING PICKHOLES

NOTES:

- 1- COVER: STEEL, HOT DIP GALVANIZED AFTER FABRICATION.
WEIGHT: 210 LBS. APP.
- 2- RING: ASTM-A48 CLASS 35B GRAY IRON.
WEIGHT: 210 LBS. APP.
- 3- LOADING: 280 P.S.I.

U.S.F. FOUNDRY & MFG. CORP..
MEDLEY, FLORIDA

USF 8605 RING & GX COVER