

(2) PENETRATING PICKHOLES

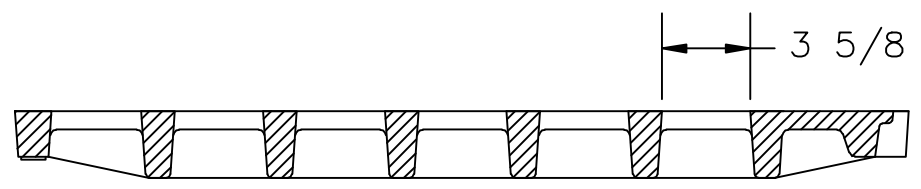
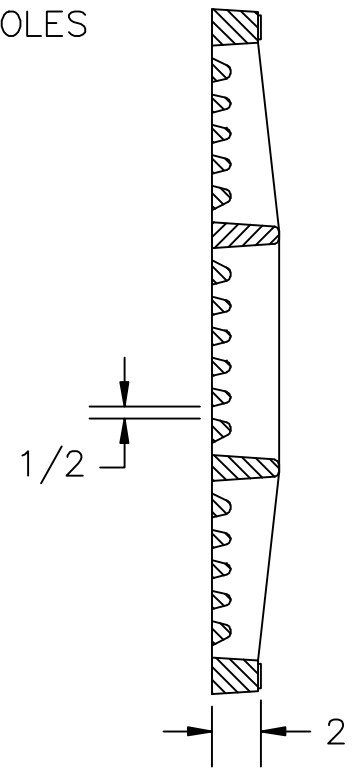

SECTION A-A

NOTE:

- 1- FLOW AREA = 240 SQ. IN. APP.
- 2- ADA Grate

U.S. FOUNDRY & MFG. CORP.
 MEDLEY, FLORIDA

DESCRIPTION:
 USF 6450 GRATE

MATERIAL: ASTM-A48 GRAY IRON CLASS: 35B
 FRAME WEIGHT: GRATE WEIGHT: 280

UNLESS OTHERWISE NOTED WEIGHT IS IN POUNDS AND APPROXIMATED

DWN. BY: AWS	SCALE: 1/8" = 1"	ITEM No: 8070195	DWG. No: A3007	DWG DATE: 07-20-93
REV BY:	CHK. BY:			REV:

REV:	DATE:	DESCRIPTION:
------	-------	--------------

REV BY:	CHK. BY:			
---------	----------	--	--	--