

MACHINED SURFACES

4- 1 5/8 DIA. ANCHOR HOLES

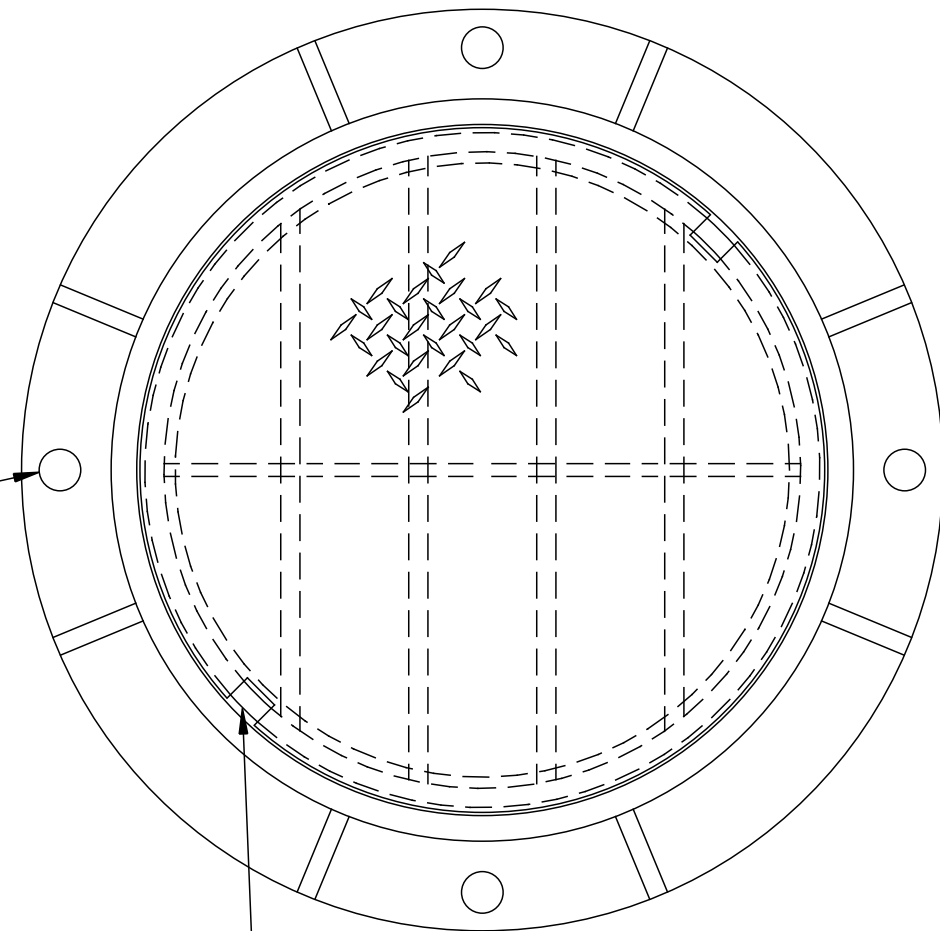
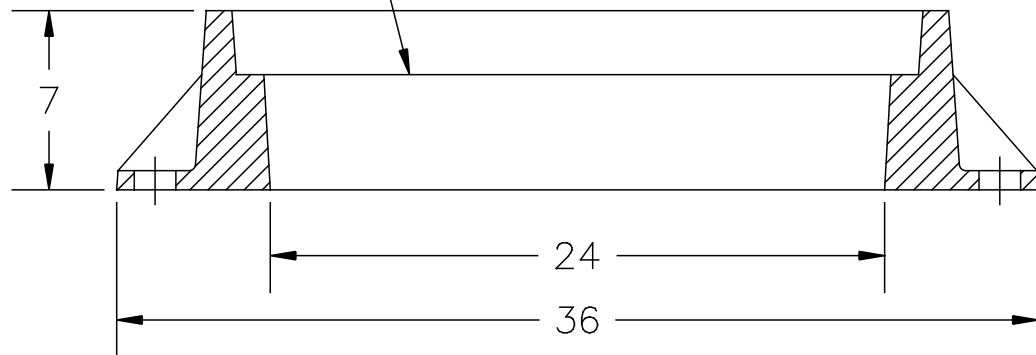

(2)- NON PENETRATING PICKHOLES

NOTES:

- 1- COVER: STEEL, HOT DIP GALVANIZED AFTER FABRICATION.
WEIGHT: 240 LBS. APP.
- 2- RING: ASTM-A48 CLASS 35B GRAY IRON.
WEIGHT: 395 LBS. APP.
- 3- LOADING: 280 P.S.I.

U.S. FOUNDRY & MFG. CORP.
MEDLEY, FLORIDA

USF 8606 RING & GX COVER